



CATALOGO 2018

Av. Brasil Qd. 04 Lt. 02 Bairro Vera Cruz - Aparecida de Goiânia - Goiás | 74 976-195
www.aliancaaluminio.com.br Fone:(62) 3584-3661 e-mail: aliancavendas@terra.com.br



Empresa

Fundada em 06 de outubro de 1999, a Aliança Alumínio com sede em Aparecida de Goiânia-GO, é pioneira em extrusão de alumínio no Centro-Oeste. Com objetivo de explorar comercialmente e industrialmente, o processo de fundição e extrusão do alumínio e suas ligas.

Visão

Ser referência no segmento buscando continuamente um padrão de excelência para nossos produtos e serviços, inovando e aprimorando os produtos de extrusão.

Missão

Atender aos nossos clientes com excelência oferecendo-lhes produtos de alta qualidade no menor tempo possível.

Alumínio

Uma excepcional combinação de propriedades faz do alumínio um dos mais versáteis materiais utilizados na engenharia, arquitetura e indústria em geral. Por isso, o metal é um dos mais utilizados no mundo todo. Material leve, durável e bonito, o alumínio mostra uma excelente performance e propriedades superiores na maioria das aplicações. Produtos que utilizam o alumínio ganham também competitividade, em função dos inúmeros atributos que este metal incorpora, como pode ser conferido a seguir:

- ❖ Leveza
- ❖ Elevada condução de energia
- ❖ Impermeabilidade e opacidade
- ❖ Alta relação resistência/peso
- ❖ Beleza
- ❖ Durabilidade
- ❖ Maleabilidade e soldabilidade.
- ❖ Resistência à corrosão
- ❖ Resistência e dureza
- ❖ Possibilidade de muitos acabamentos
- ❖ Infinitamente reciclável



Reciclagem

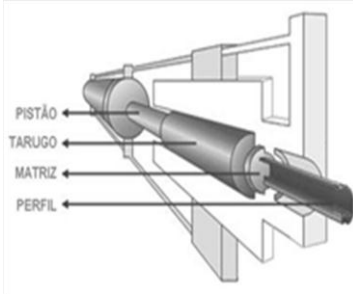

O Alumínio é o primeiro nome lembrado quando o assunto é reciclagem. A reciclabilidade é um dos principais atributos do metal e reforça a vocação de sua indústria para a sustentabilidade em termos econômicos, sociais e ambientais. O alumínio pode ser reciclado infinitas vezes, sem perder suas características e propriedades físico-químicas no processo de reaproveitamento, ao contrário de outros materiais.

O alumínio pode ser reciclado tanto a partir de sucatas geradas por produtos de vida útil esgotada, quanto por sobras do processo produtivo. Utensílios domésticos, esquadrias de janelas, componentes automotivos, entre outros, podem ser fundidos e empregados novamente na fabricação de novos produtos.



Qualidade



As ligas de alumínio utilizadas nas diversas aplicações têm limites de composição química, propriedades mecânicas e outras características estabelecidas pelas normas da Associação Brasileira de Normas Técnicas (ABNT), independentemente da liga trabalhada ser primária, reciclada ou mista.

Extrusão

É um processo de conformação que consiste em forçar um tarugo sob a pressão de um pistão, através da abertura de uma matriz. Neste processo, praticamente qualquer forma de seção transversal, vazada ou cheia, pode ser produzida. Como a geometria da matriz permanece inalterada, os produtos extrudados tem seção transversal constante.

Nosso processo compõe um controle de composição e qualidade das ligas, medições, constantes pesquisas, e um acervo de matrizes, com o objetivo de atender ao mercado exigente.

Ferramentaria

Dispomos de um departamento de ferramentaria, para a produção de nossas matrizes, como também projetos exclusivos para nossos clientes, tratamento e correção de ferramentas, processos que facilitam a produção dos perfis em tempo hábil, buscando qualidade e satisfação para nossos clientes.





COMPOSIÇÃO QUÍMICA

ABNT ASTM	Si	Fe	Cu	Mn	Mg	Cr	Zn	Ti	Outros Elementos		Alumínio (mínimo)
									Cada	Total	
6060	0,30-0,60	0,10-0,30	0,10	0,10	0,35-0,70	0,05	0,15	0,10	0,05	0,15	Restante
6061	0,40-0,80	0,70	0,15-0,40	0,15	0,80-1,20	0,04-0,35	0,25	0,15	0,05	0,15	Restante
6063	0,20-0,60	0,35	0,10	0,10	0,45-0,90	0,10	0,10	0,10	0,05	0,15	Restante
6101	0,30-0,70	0,50	0,10	0,03	0,35-0,80	0,03	0,10	–	0,03	0,10	Restante
6261	0,40-0,70	0,40	0,15-0,40	0,20-0,35	0,7-1,0	0,10	0,20	0,10	0,05	0,15	Restante
6351	0,70-1,30	0,50	0,10	0,40-0,80	0,40-0,85	–	0,20	0,20	0,05	0,15	Restante
6463	0,20-0,60	0,15	0,20	0,05	0,45-0,90	–	0,05	0,03	0,05	0,15	Restante

APLICAÇÕES TÍPICAS

6060	Esquadrias em geral, ornamentos, divisórias, forros e box, apropriado para anodização decorativa fosca.
6061	Estruturas solicitadas, caminhões, móveis, reboques, vagões, oleodutos e rebites.
6063	Tubos de irrigação e acabamento de carrocerias, apropriado para anodização decorativa fosca.
6101	Condutores e barramentos elétricos.
6261	Carrocerias de veículos, estruturas e equipamentos e vergalhões para usinagem.
6351	Estruturas solicitadas, coberturas, peças usinadas, veículos e equipamentos.
6463	Frisos brilhantes para autos e eletrodomésticos e perfis brilhantes para uso geral (alto brilho).

ÍNDICE

BARCOS	4
BARRA CHATA	6
BOX FRIZADO CONVENCIONAL-TRADICIONAL	7
BOX FRIZADO SORO	8
BOX - BANHEIRO VIDRO TEMP.	9
CANTONEIRAS	11
CARROCERIAS	12
CASE	13
CONTRAMARCO	15
DIVERSOS	16
MACHOS E CONEXÕES	18
MÓVEIS	19
PERFIL U	25
PERSIANAS-DECORAÇÃO	26
SALA LIMPA	27
TOLDO	28
TRILHO - CORTINA	29
TRILHO - CORTINA SUÍÇO	30
TUBO QUADRADO	32
TUBO REDONDO	33
TUBO RETANGULAR - RÉGUAS	35
VENEZIANAS	36
VIDRO TEMPERADO 8mm	37
VIDRO TEMPERADO 10mm	40
VITRINE E BALCÕES	42

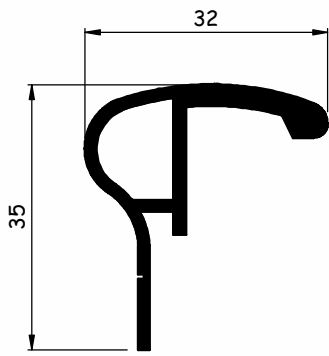

AL119 (DS-122)
0,460 kg/m

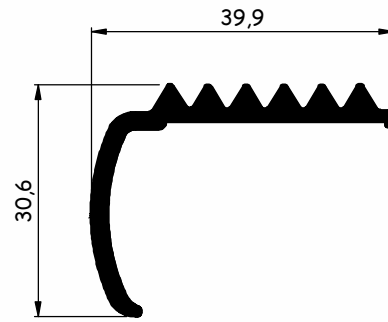

AL120
0,480 kg/m

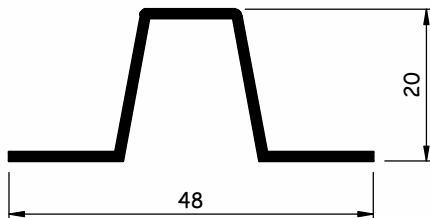

AL289L (DS-028)
0,253-0,291 kg/m
AL289P
0,300-0,350 kg/m

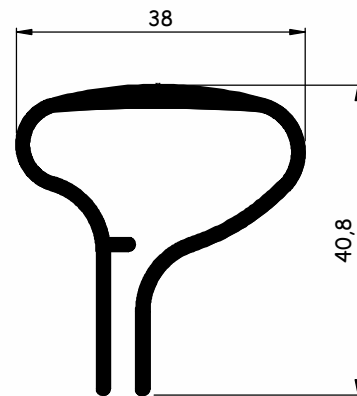

AL194 (DS-194 ROTAL)
0,625-0,720 kg/m

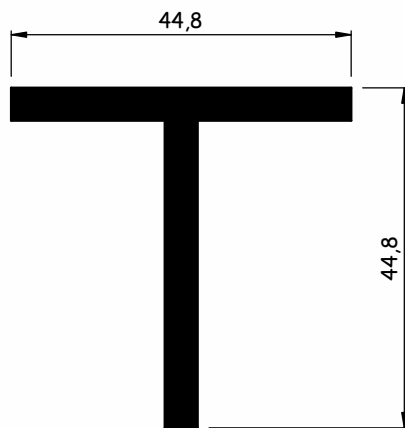

AL118
0,490 kg/m

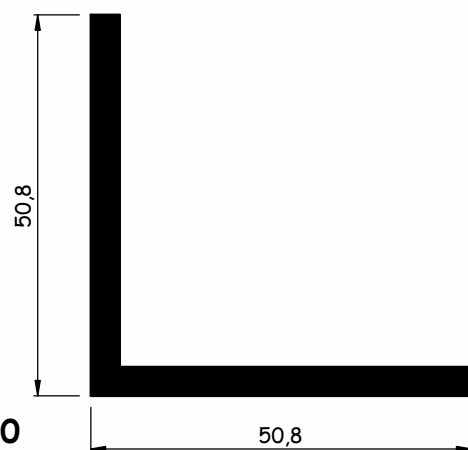

AL320
0,830 kg/m

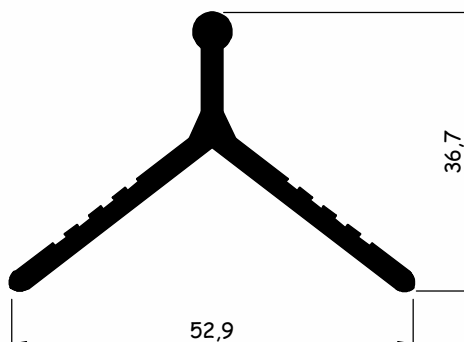

AL900
0,595 kg/m

BARCOS

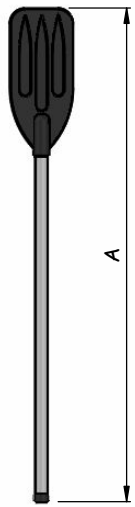

CÓDIGO	METROS
	A
REMO 1,30 L	1,30
REMO 1,30 RF	1,30
REMO 1,50 L	1,50
REMO 1,50 RF	1,50

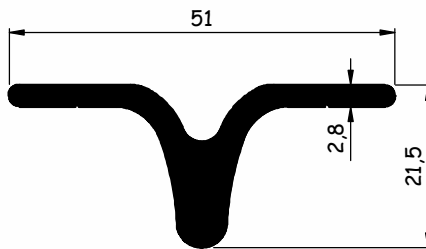

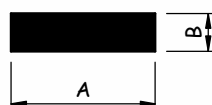

CÓDIGO	POLEGADA*		MILÍMETROS		PESO (kg/m)
	A	B	A	B	
AL061	1/2	3/32	12,70	2,40	0,082
AL071	1/2	1/16	12,70	1,58	0,049-0,060
AL020	33/64	3/32	13,00	2,40	0,093-0,108
AL005	33/64	9/64	13,00	3,50	0,125
AL007	37/64	9/64	14,80	3,47	0,140
AL025	5/8	1/8	15,80	3,18	0,120
AL018	1	3/16	25,40	4,76	0,310
AL017	1.1/2	3/8	38,10	9,52	0,980
AL024	1.3/4	5/32	44,45	3,96	0,300
AL008	2	1/8	50,80	3,18	0,410
AL016P	2. 5/16	1/8	59,20	3,00	0,480
AL016L	2. 5/16	7/64	59,40	2,60	0,380

*Algumas medidas em polegada estão em valores aproximados.

BOX FRIZADO CONVENCIONAL/TRADICIONAL

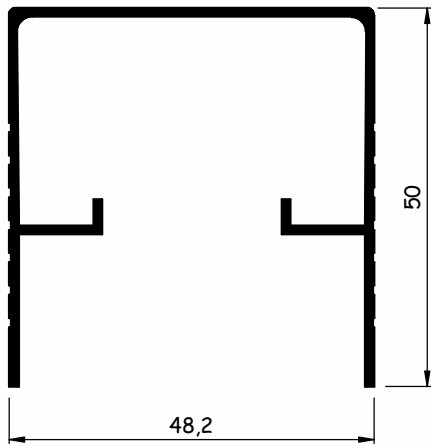

AL041C-P (BX-183)
0,554 kg/m

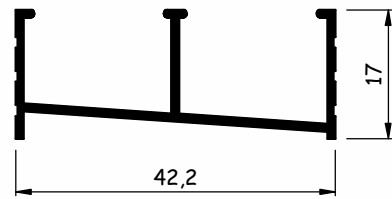

AL031C-P (BX-175)
0,250 kg/m

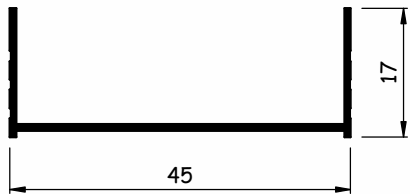

AL052C (BX-174)
0,180 kg/m

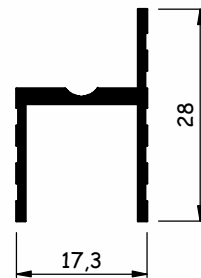

AL068C (BX-106)
0,210 kg/m

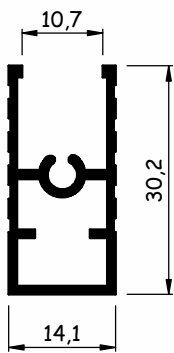

AL140C (BX-101)
0,276 kg/m

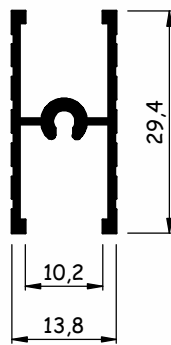

AL049C (BX-159)
0,230 kg/m

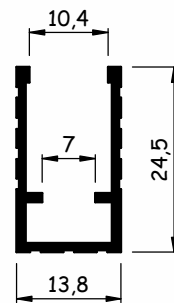

AL046C (BX-158)
0,160-0,200 kg/m

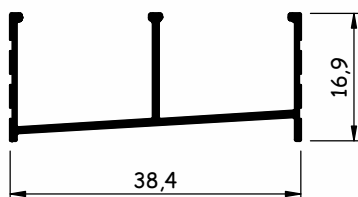

AL031C-L
0,182 kg/m

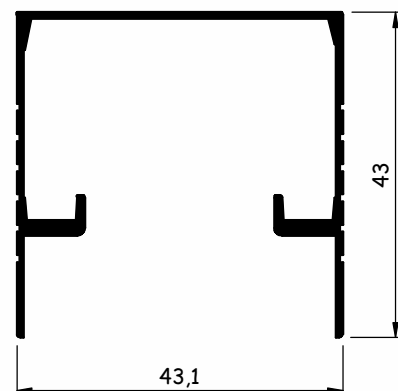

AL041C-L
0,407 kg/m

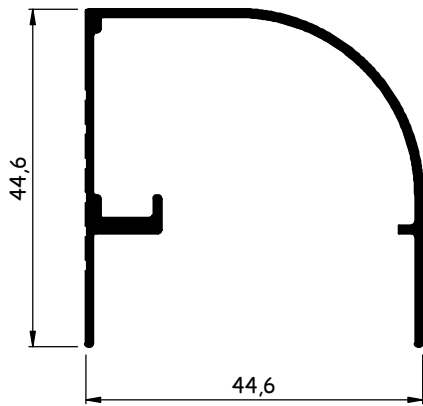

AL042S (BX-084)
0,410 kg/m

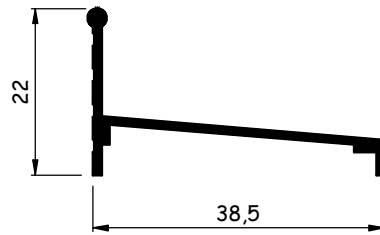

AL032S
0,200 kg/m

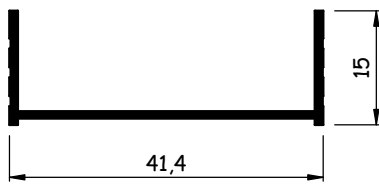

AL051S
0,190 kg/m

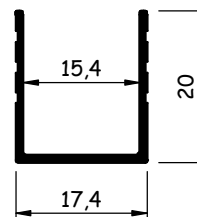

AL069S (BX-112)
0,150-0,185 kg/m

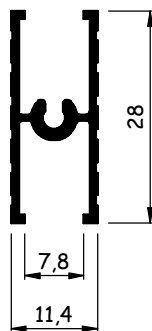

AL050S
0,210 kg/m

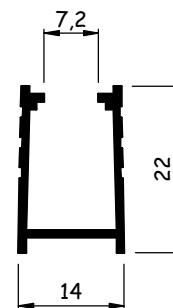

AL047S
0,170 kg/m

BOX P/ BANHEIRO VIDRO TEMP.

9

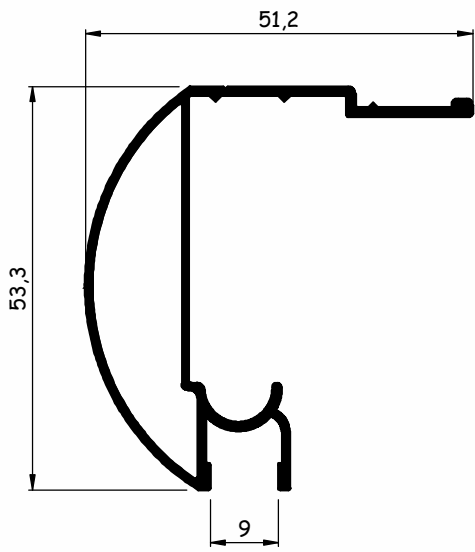

AL8126 (BX-084)
0,609 kg/m

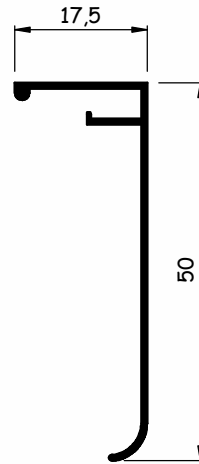

AL8865 (BX-500)
0,316 kg/m

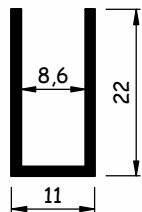

AL839
0,150-0,170 kg/m

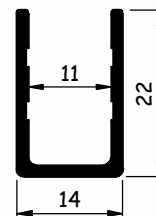

AL838L 0,125 - 0,145 kg/m
AL838P 0,155 - 0,180 kg/m

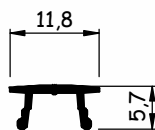

AL810
0,060 kg/m

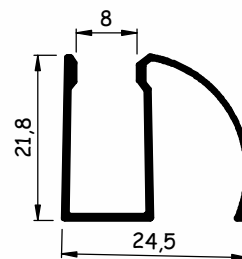

AL805L
0,172 kg/m

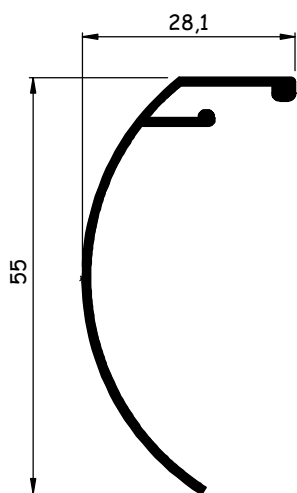

AL862

0,255 kg/m

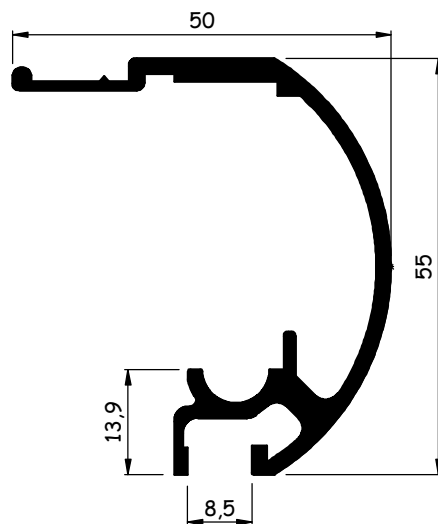

AL863

0,815 kg/m

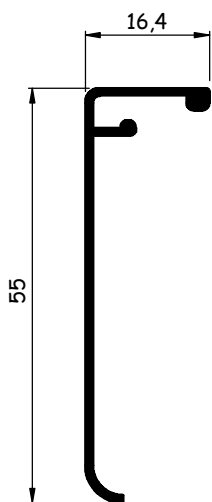

AL864

0,230 kg/m

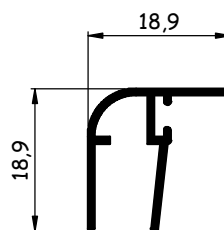

AL837

0,143 kg/m

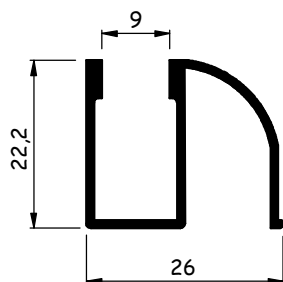

AL805P (BX-086)

0,245 kg/m

ABAS IGUAIS

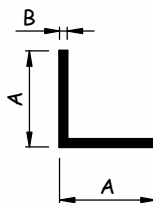

CÓDIGO	POLEGADA*		MILÍMETROS		PESO (kg/m)
	A	B	A	B	
AL014	1/2	1/16	12,70	1,58	0,095
AL080	5/8	1/16	15,87	1,58	0,120
AL009L	3/4	5/128	19,05	1,00	0,095-0,110
AL009P	3/4	1/16	19,05	1,58	0,150
AL013	1	1/16	25,40	1,58	0,200
AL081	1	1/8	25,40	3,00	0,383-0,442
AL085	1.1/32	9/64	26,12	3,57	0,450
AL030	1.1/4	9/64	31,75	3,57	0,495
AL019	1.1/4	3/16	31,75	4,76	0,745
AL026	1.1/2	9/64	38,10	3,57	0,670
AL320	2	1/8	50,80	3,17	0,830
AL320L	2	1/16	50,80	1,50	0,401

*Algumas medidas em polegada estão em valores aproximados.

ABAS DESIGUAIS



CÓDIGO	POLEGADA*			MILÍMETROS			PESO (kg/m)
	A	B	C	A	B	C	
AL209	1.17/64	41/64	3/64	32,00	16,20	1,20	0,152

*Algumas medidas em polegada estão em valores aproximados.

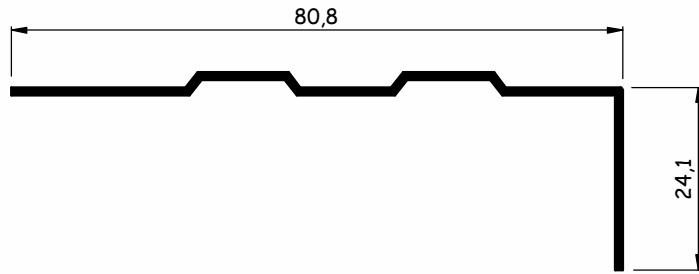

AL440
0,292 kg/m

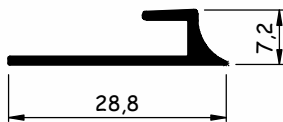

AL441
0,125 kg/m

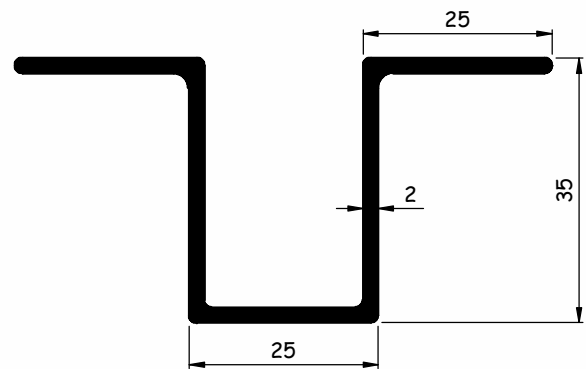

AL442
0,740 kg/m

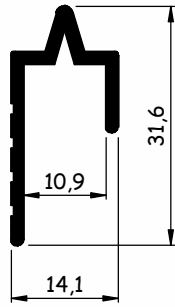

AL6002
0,235 kg/m

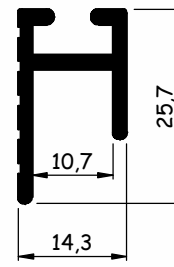

AL6001
0,289 kg/m

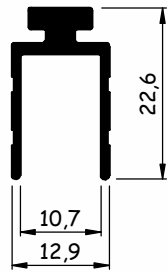

AL6018
0,230 kg/m

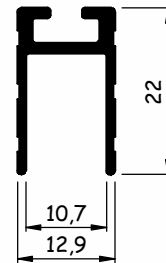

AL6019
0,200 kg/m

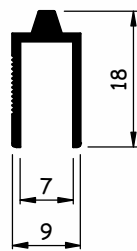

AL6008
0,120 kg/m

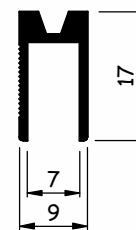

AL6009
0,138 kg/m

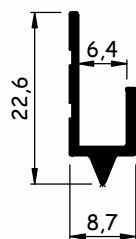

AL6015
0,120 kg/m

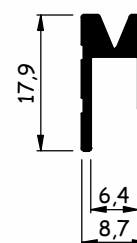

AL6016
0,161 kg/m

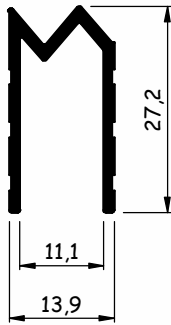

AL6014
0,296 kg/m

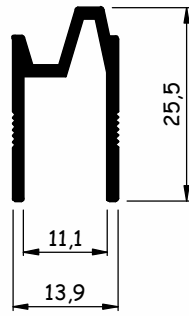

AL6005
0,238 kg/m

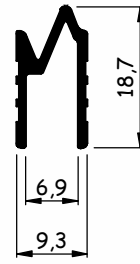

AL6013
0,137 kg/m

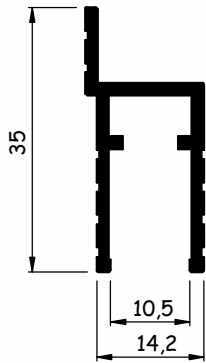

AL6007
0,319 kg/m

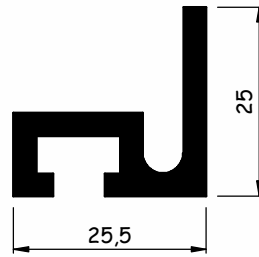

AL6010
0,560 kg/m

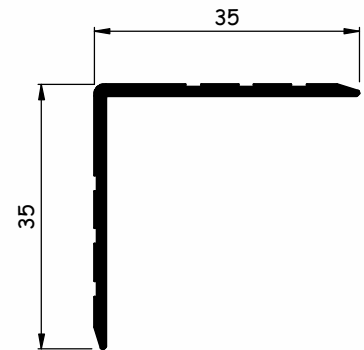

AL6017
0,258 kg/m

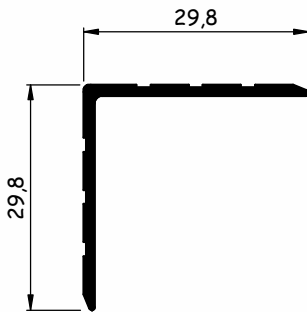

AL6006
0,217 kg/m

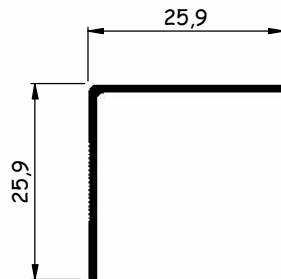

AL6004
0,148 kg/m

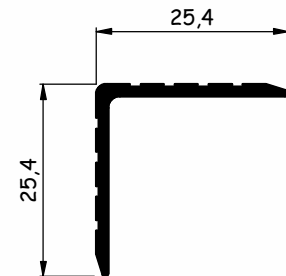

AL6003
0,200 kg/m

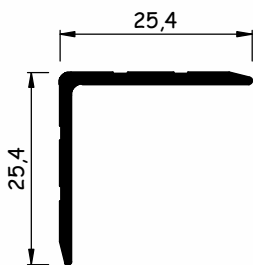

AL6021
0,189 kg/m

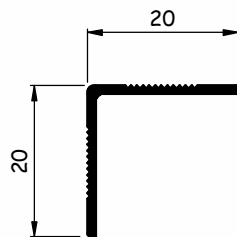

AL6011
0,110 kg/m

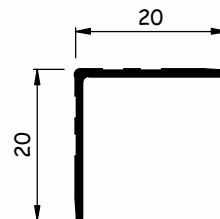

AL6020
0,087 kg/m

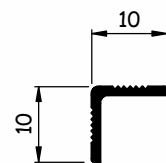

AL6012
0,060 kg/m

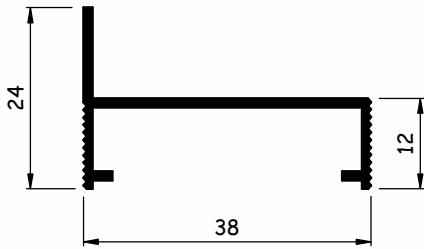

AL060 (CM-060)
0,240 kg/m

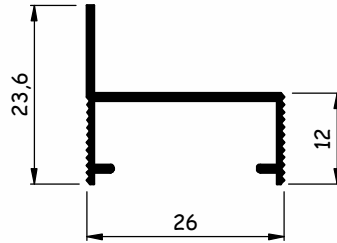

AL063P 0,150-0,165 kg/m (*CM-200*)
AL063L 0,133-0,148 kg/m

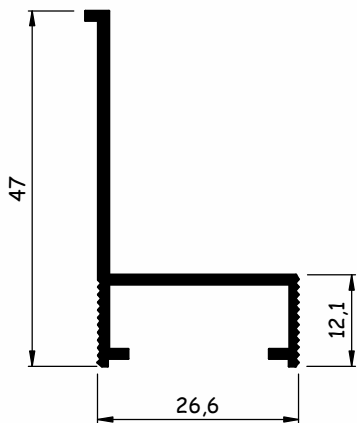

AL151 (CM-151)
0,320 kg/m

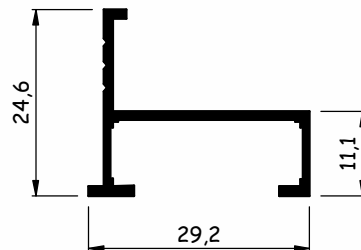

AL110 (CM-110)
0,210 kg/m

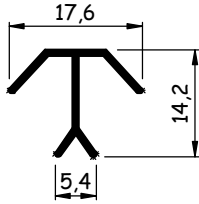

AL264 (DS-264)
0,086 kg/m

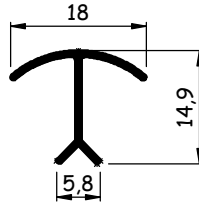

AL265
0,084 kg/m



AL043
0,146 kg/m

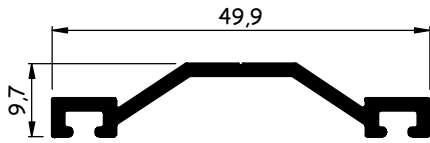

AL931
0,305 kg/m

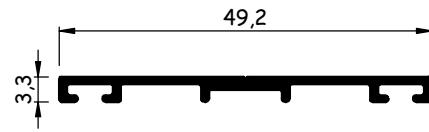

AL932
0,199 kg/m

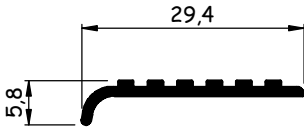

AL341
0,083 kg/m

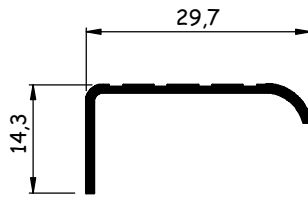

AL340
0,114 kg/m

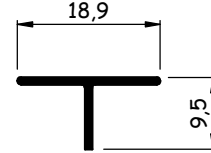

AL179
0,067 kg/m

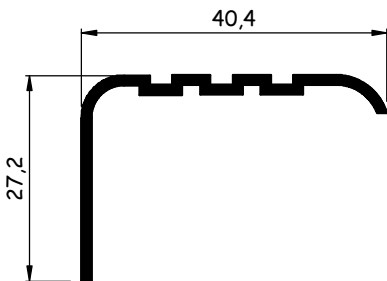

AL130
0,256 kg/m

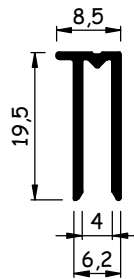

AL415
0,132 kg/m

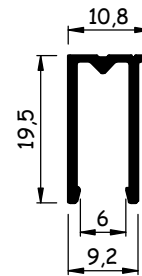

AL641
0,143 kg/m

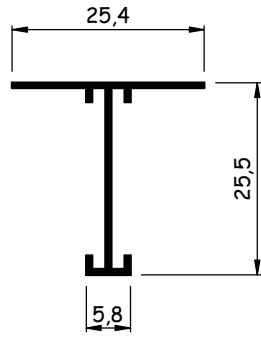

AL180L (DS-202)
0,110-0,130 kg/m

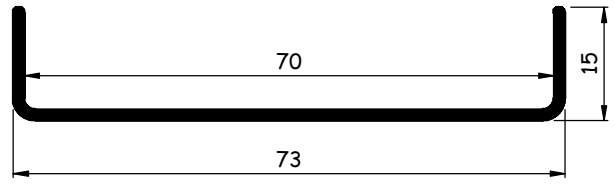

AL131
0,386 kg/m

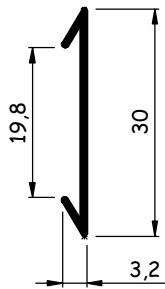

AL073
0,083 kg/m

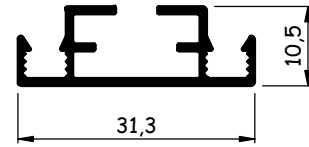

AL150
0,208 kg/m

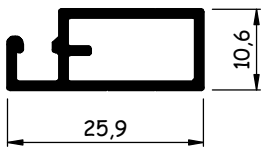

AL149
0,220 kg/m

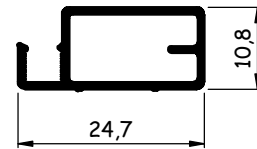

AL148
0,175 kg/m

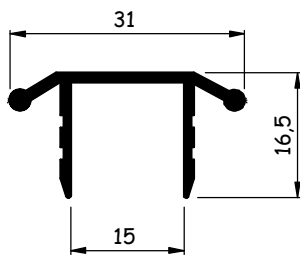

AL072
0,082 kg/m

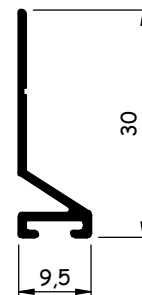

AL266
0,117 kg/m

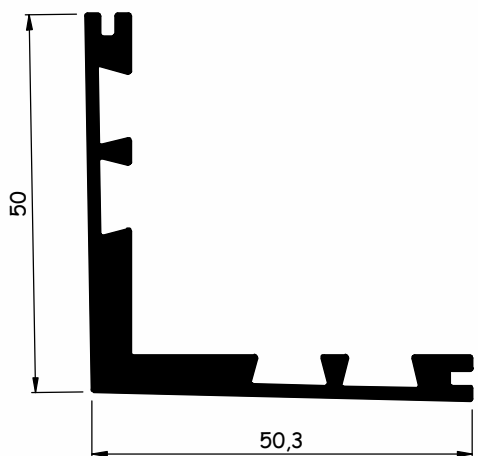

AL006 (CL-006)
0,970 kg/m

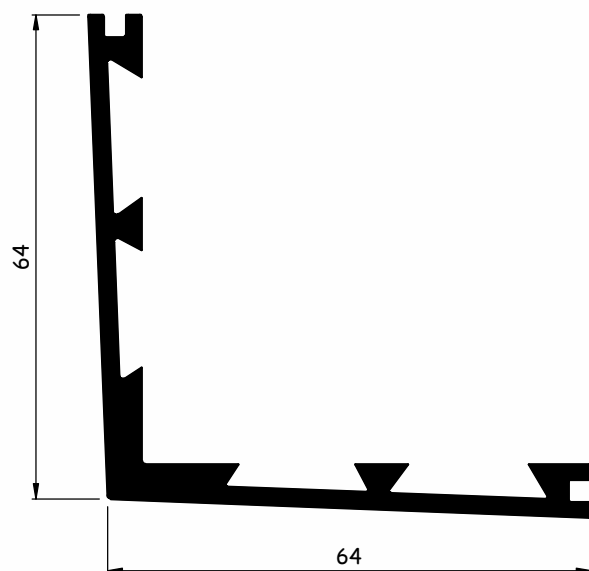

AL044 (CL-044)
1,600 kg/m

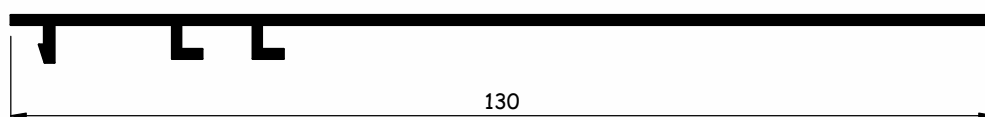

AL175 (CM-175)
0,349 kg/m

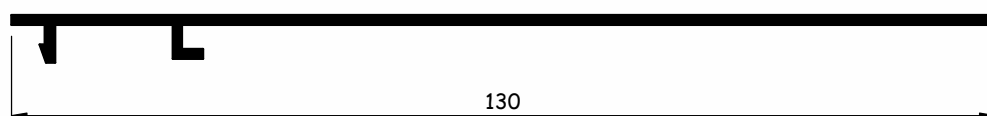

AL099 (CM-099)
0,338 kg/m

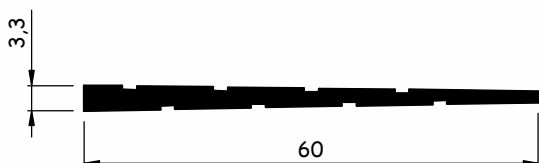

AL010 (CL-010)
0,365 kg/m

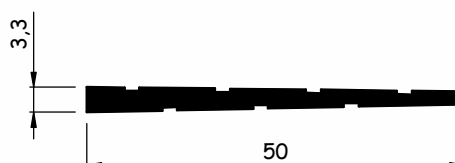

AL011 (CL-011)
0,320 kg/m

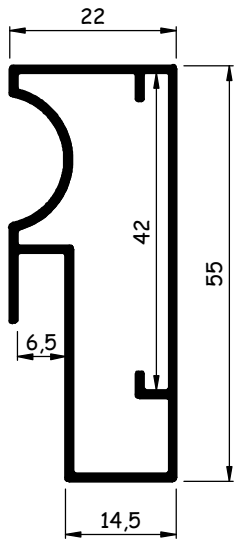

AL1528P
0,520-0,600 kg/m

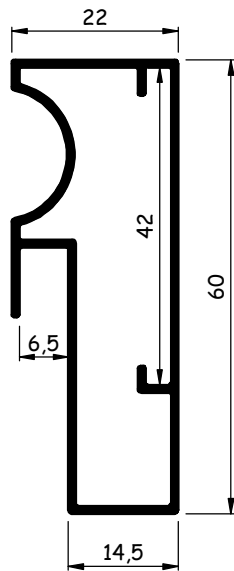

AL1528L (BK-498)
0,430-0,500 kg/m

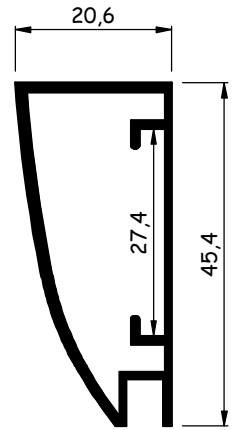

AL114 (BK-354)
0,420 kg/m

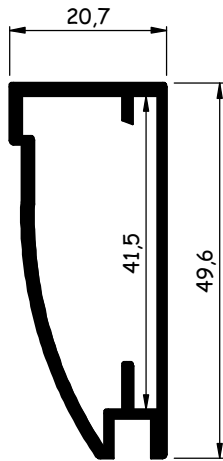

AL1529 (BK-354)
0,547 kg/m

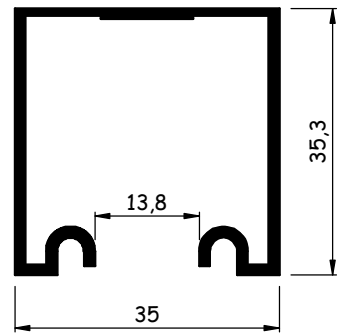

AL065 (DS-266)
0,490 kg/m

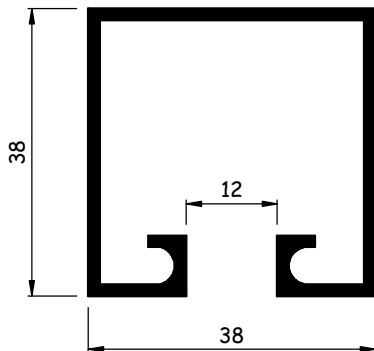

AL066 (DS-152)
0,640 kg/m

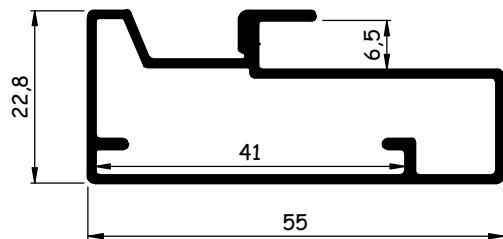

AL1480
0,433-0,500 kg/m

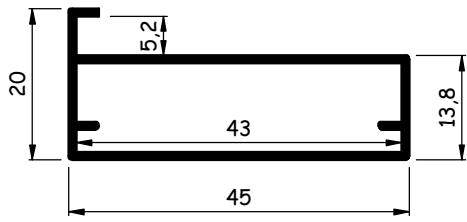

AL1501
0,340 kg/m

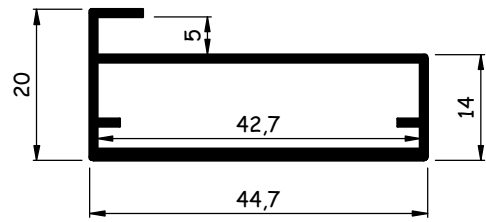

AL1502
0,459 kg/m

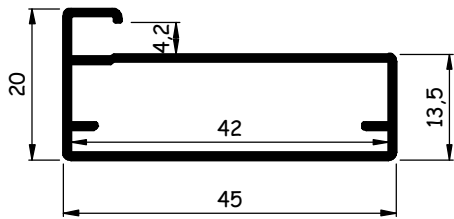

AL1536 (SP-1036)
0,395 kg/m

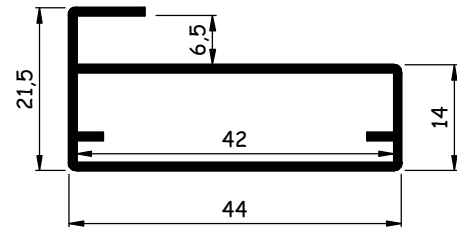

AL1499
0,497kg/m

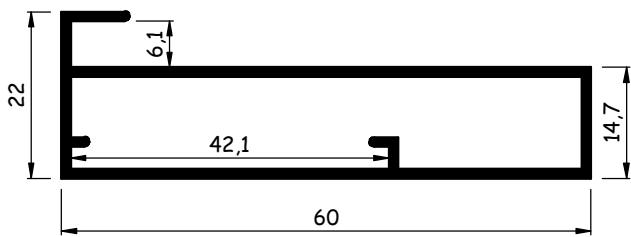

0,546 kg/m

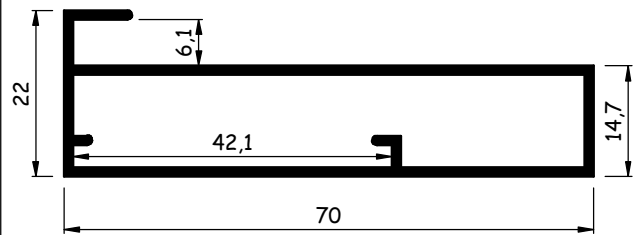

0,610 kg/m

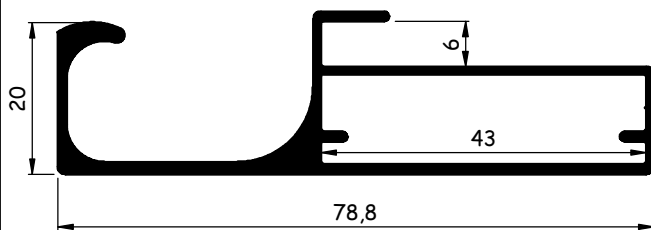

AL1566
0,768 kg/m

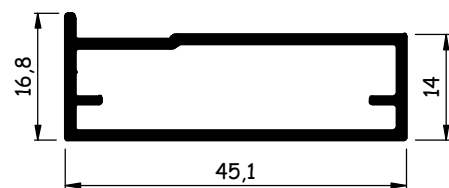

AL1506
0,426 kg/m

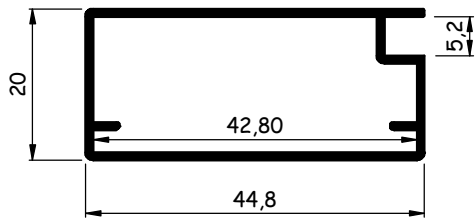

AL1518 (BK-518)
0,492 kg/m

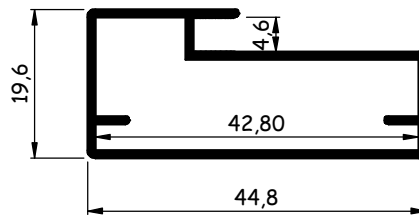

AL1517 (BK-517)
0,489 kg/m

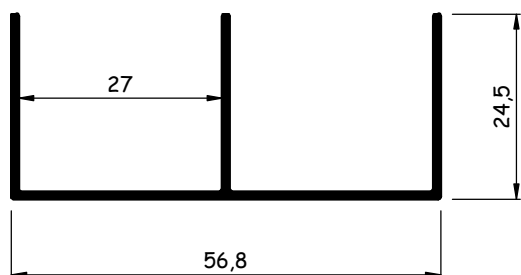

AL1516 (BK-516)
0,327 kg/m

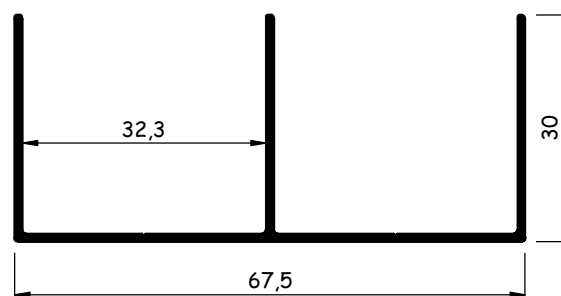

AL1519
0,420 kg/m

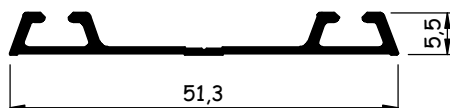

AL1005
0,190 kg/m

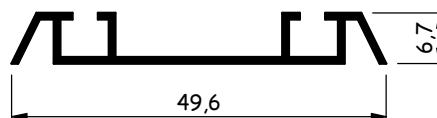

AL1002 (SP-014)
0,200 kg/m

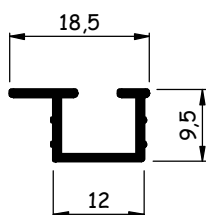

AL1031
0,109 kg/m

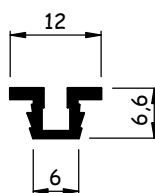

AL1032
0,083 kg/m

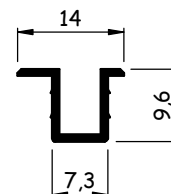

AL1030
0,076 kg/m

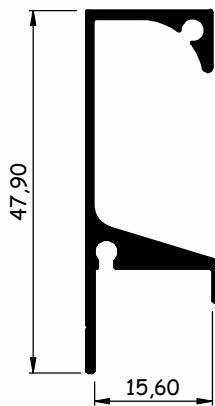

AL1544
0,370 kg/m

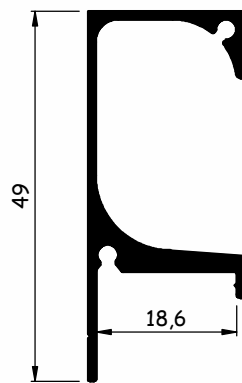

AL1547
0,403 kg/m

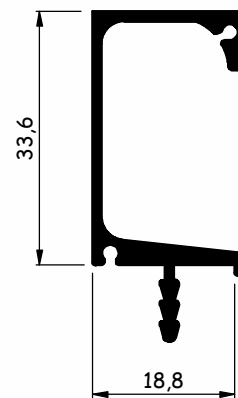

AL1533
0,398 kg/m

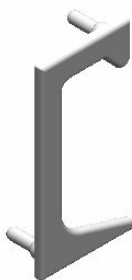

ALMR02 (BRILHANTE-AL1544)
ALMR03 (FOSCO-AL1544)



ALMR00 (FOSCO-AL1544)
ALMR01 (BRILHANTE-AL1544)
ALMR85 (FOSCO-AL1533)
ALMR86 (BRILHANTE-AL1533)
ALMR875 (BRILHANTE-AL1547)
ALMR876 (FOSCO-AL1547)
ALMR877 (FOSCO-AL1531)
ALMR878 (BRILHANTE-AL1531)

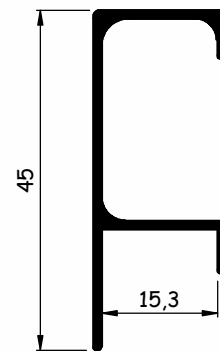

AL1531 (AT-218)
0,280 kg/m

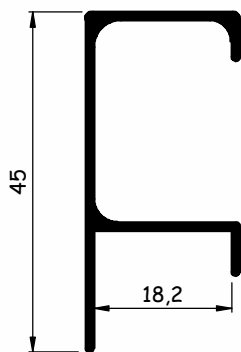

AL1532 (AT-219)
0,297 kg/m

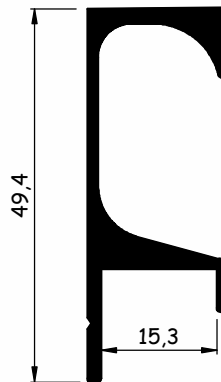

AL1545 (SP-047/BK-545)
0,541 kg/m

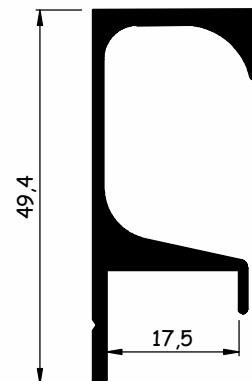

AL1546 (SP-046/BK-546)
0,575 kg/m

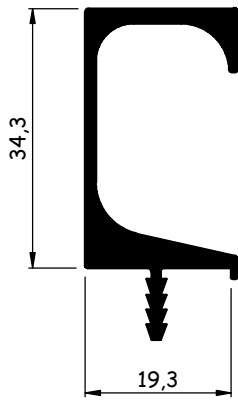

AL1530 (BK-501)
0,540 kg/m

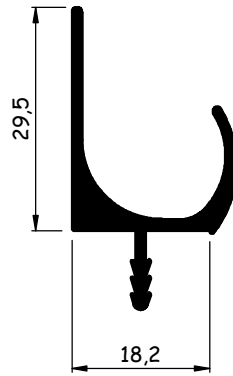

AL1527
0,376 kg/m

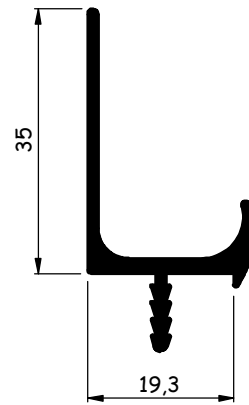

AL1505
0,320 kg/m

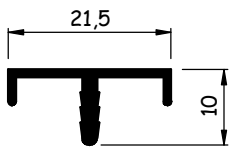

AL1541 (SP-020A)
0,150 kg/m

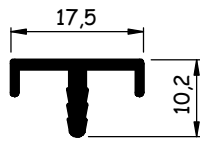

AL1515
0,132 kg/m

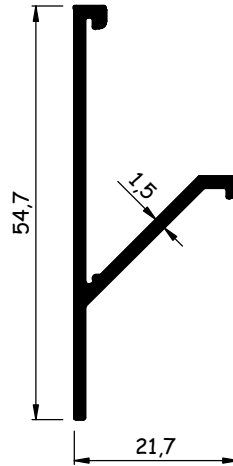

AL1534
0,353 kg/m

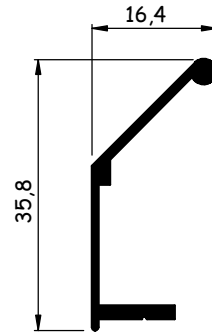

AL1513
0,175 kg/m

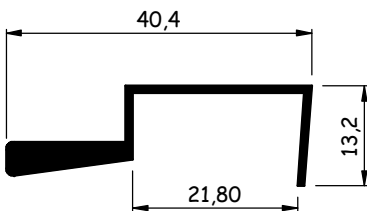

AL1503 (BK-503)
0,215 kg/m

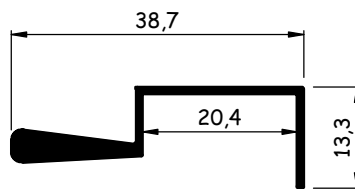

AL1512
0,240 kg/m

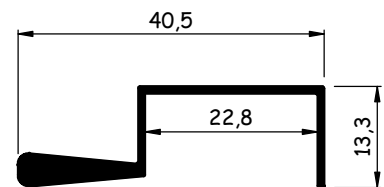

AL15XX
0,245 kg/m

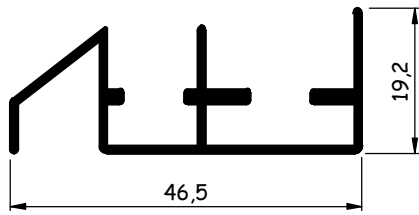

AL1509
0,365 kg/m

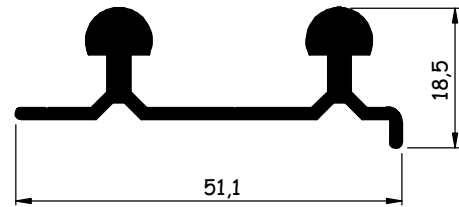

AL1510
0,553 kg/m

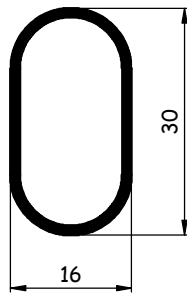

AL1001 (TUB-001)
0,284 kg/m

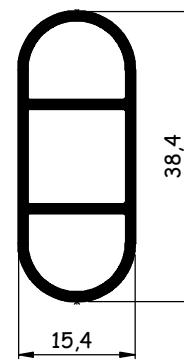

AL1022
0,378 kg/m

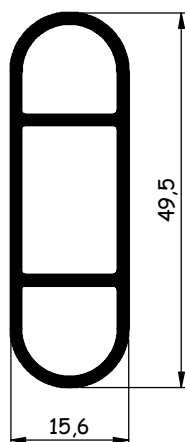

AL1023
0,525 kg/m

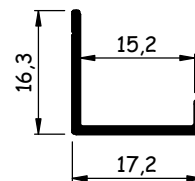

AL1511
0,100 kg/m

PERFIL U

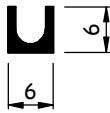

AL033 (CG105)
0,050 kg/m

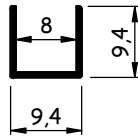

AL036
0,050 kg/m

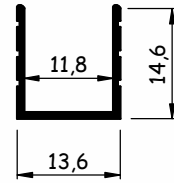

AL062
0,085-0,100 kg/m

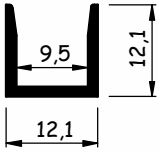

AL835
0,113 kg/m

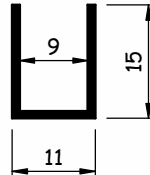

AL840
0,117 kg/m

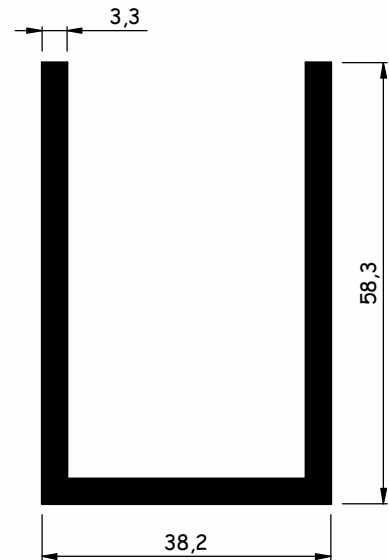

AL342
1,32 kg/m

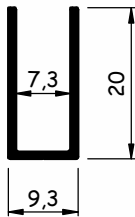

AL152
0,127 kg/m

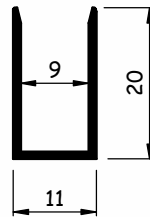

AL841
0,125-0,145 kg/m

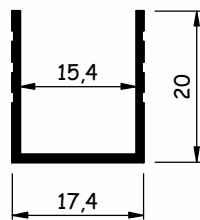

AL069 (BX-112)
0,150-0,185 kg/m

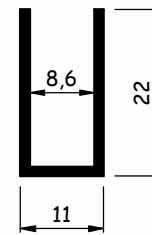

AL839
0,150-0,170 kg/m

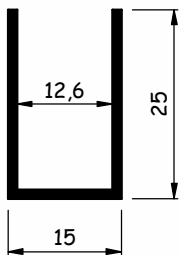

AL555 (PU-344)
0,210 kg/m

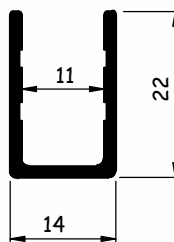

AL838L 0,125 - 0,145 kg/m
AL838P 0,155 - 0,180 kg/m

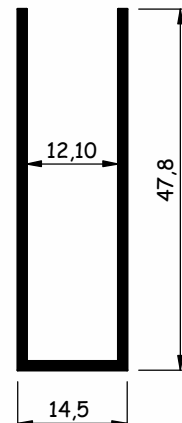

AL836
0,350 kg/m



AL031
0,047 kg/m

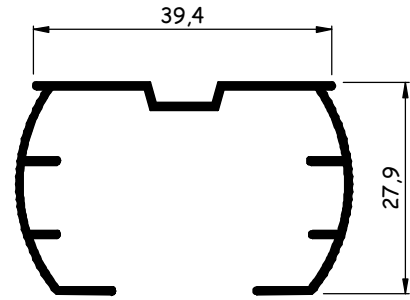

AL064
0,250-0,285 kg/m



AL732
0,042 kg/m



AL733
0,112 kg/m

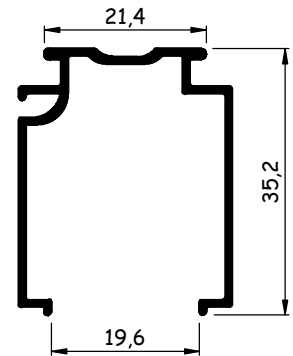

AL734
0,286 kg/m

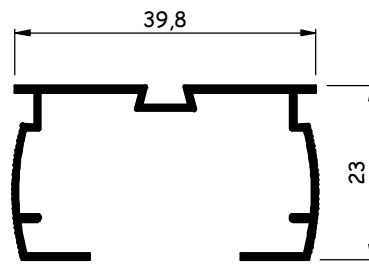

AL067
0,220 kg/m

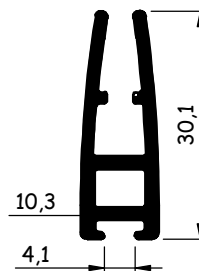

AL759
0,342 kg/m

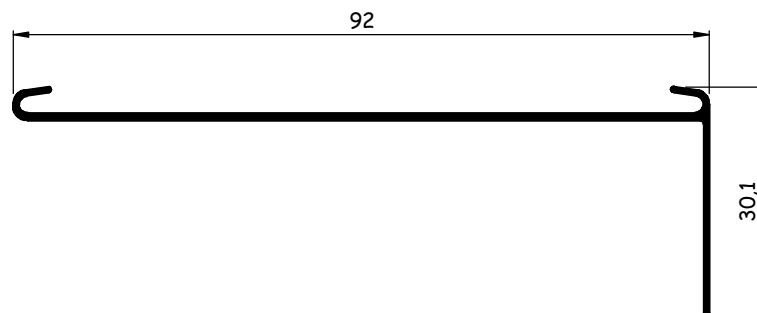

AL111L
0,265-0,300 kg/m

AL111P
0,310-0,355 kg/m

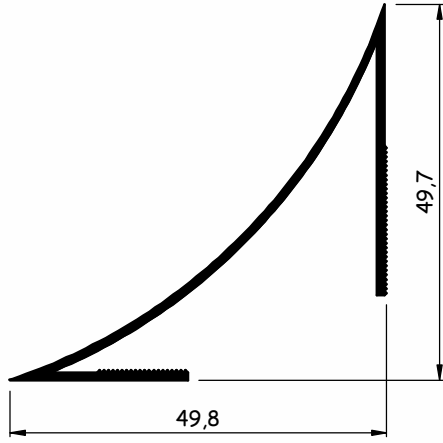

AL105 (TR-CX105)
0,600 kg/m

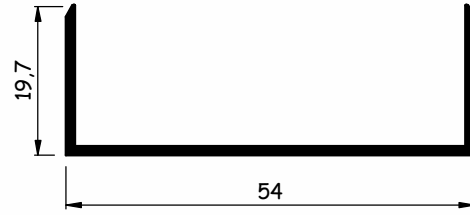

AL077
0,292 kg/m

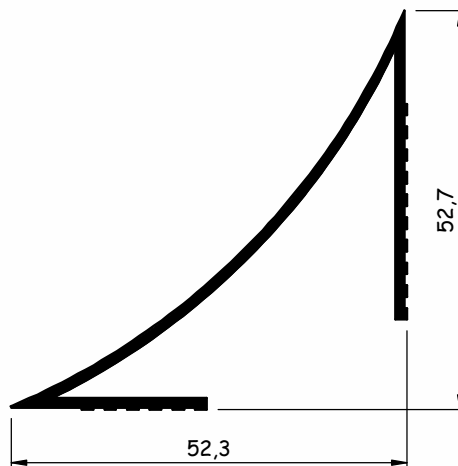

AL105L
0,430 kg/m

AL758

0,760 kg/m

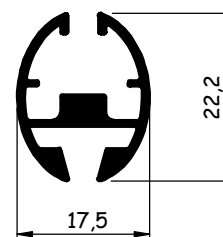
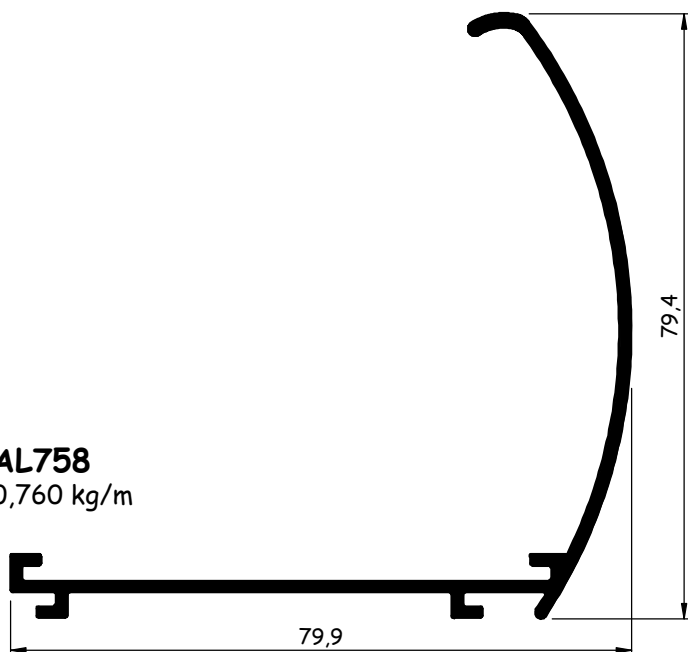

AL756

0,280 kg/m

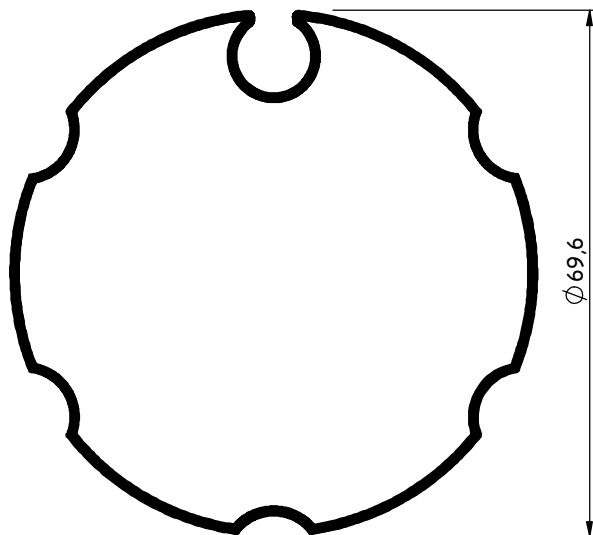

AL904

0,752 kg/m

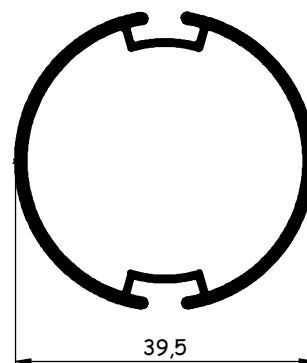

AL757

0,478 kg/m

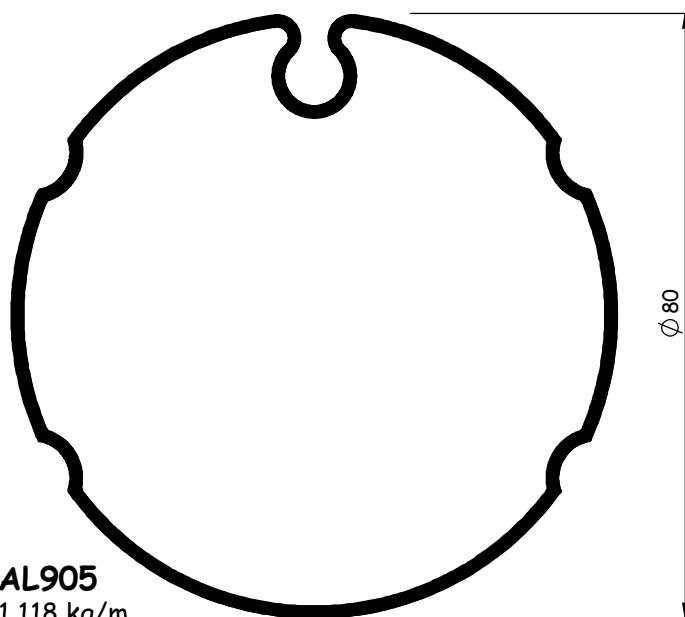

AL905

1,118 kg/m

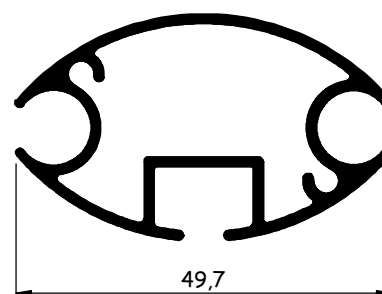

AL906

0,630 kg/m

TOLDO

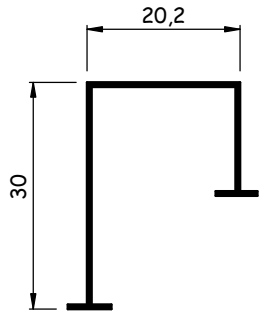

AL001L
0,115 kg/m

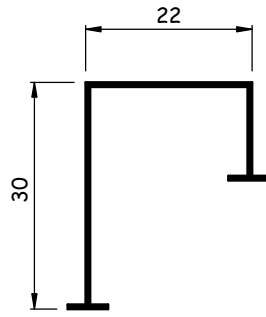

AL001M
0,119 kg/m

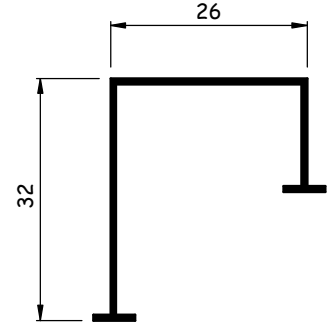

AL001P
0,160 kg/m

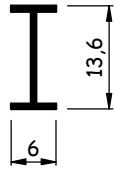

AL100
0,043 kg/m

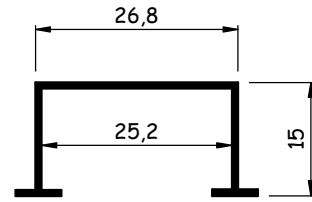

AL003
0,150 kg/m

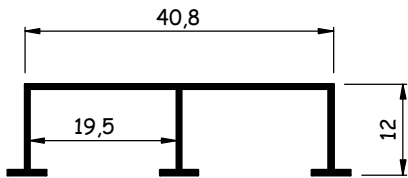

AL002L
0,167 kg/m

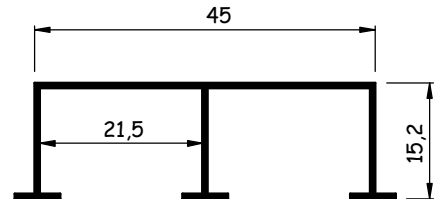

AL002P
0,184 kg/m

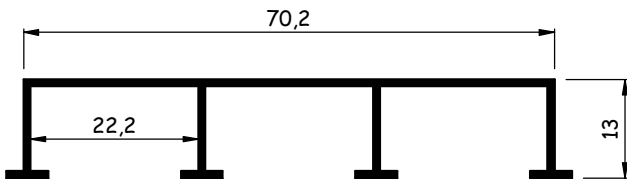

AL004P
0,313 kg/m

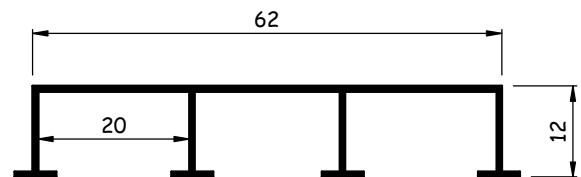

AL004L
0,240 kg/m

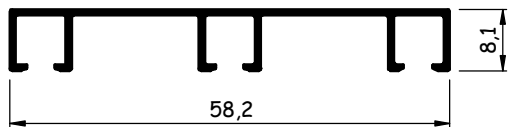

AL729
0,230 kg/m

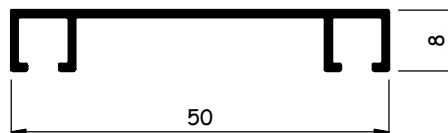

AL728
0,210 kg/m

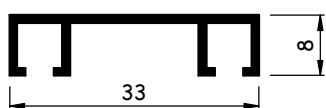

AL727
0,180 kg/m

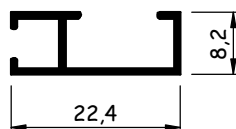

AL731
0,122 kg/m

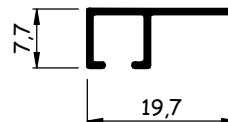

AL726
0,095 kg/m

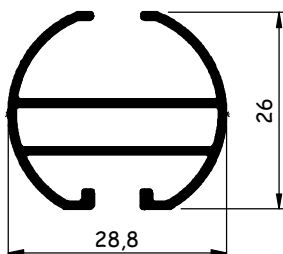

AL755
0,350 kg/m

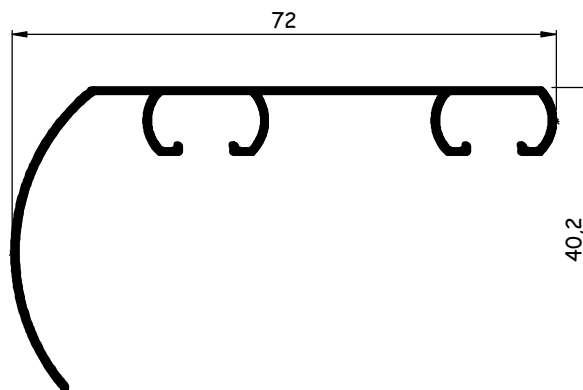

AL754
0,330 kg/m

TRILHO P/ CORTINA SUIÇO

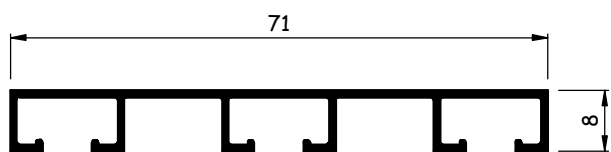

AL722
0,371 kg/m

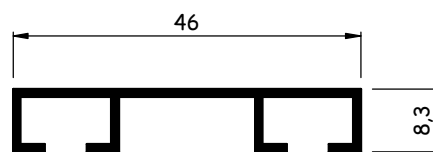

AL721
0,240 kg/m

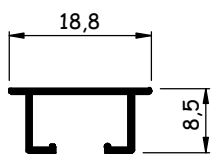

AL720
0,095 kg/m
AL720B
0,095-0,110 kg/m

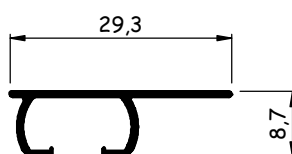

AL750
0,129 kg/m
AL750B
0,129-0,150 kg/m

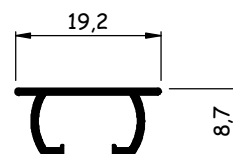

AL751
0,105 kg/m

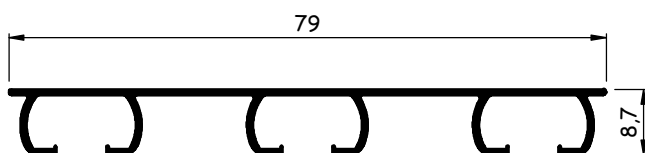

AL753
0,365 kg/m
AL753B
0,320-0,380 kg/m

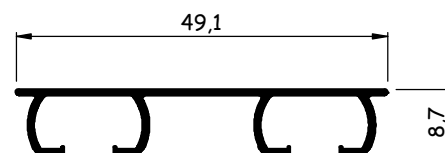

AL752
0,237 kg/m
AL752B
0,220-0,270 kg/m

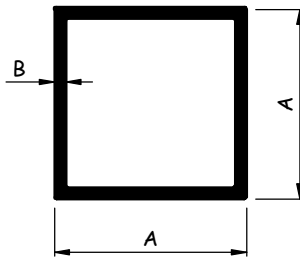

CÓDIGO	POLEGADA*		MILÍMETROS		PESO (kg/m)
	A	B	A	B	
AL1211	1/2	1/32	12,80	0,90	0,115
AL1616	5/8	1/32	15,87	0,90	0,140
AL2015	5/8	1/16	15,87	1,58	0,230
AL2020L	3/4	5/128	19,05	1,00	0,194
AL2020P	3/4	1/16	19,05	1,50	0,266
AL2525L	1	7/128	25,40	1,40	0,356
AL2525P	1	5/64	25,40	1,80	0,455
AL3838	1. 1/2	1/16	38,10	1,50	0,580
AL4020L	2	3/64	50,80	1,10	0,590
AL4020P	2	1/16	50,80	1,60	0,850

*Algumas medidas em polegada estão em valores aproximados.

TUBO REDONDO

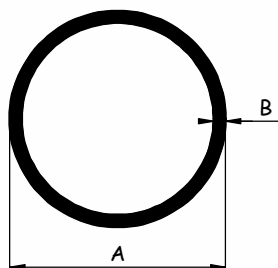

CÓDIGO	POLEGADA		MILÍMETROS		PESO (kg/m)
	A	B	A	B	
AL055	3/8	5/128	9,53	1,00	0,060-0,080
AL057	25/64	3/32	10,00	2,25	0,136-0,158
AL037	1/2	3/64	12,70	1,19	0,090-0,115
AL012	9/16	3/64	14,28	1,19	0,120-0,144
AL038	5/8	3/64	15,81	1,19	0,135-0,160
AL058L	3/4	5/128	19,00	1,00	0,138-0,173
AL058	3/4	1/16	19,00	1,60	0,223-0,250
AL034L	7/8	5/128	22,22	1,00	0,157-0,192
AL034M	7/8	1/16	22,22	1,58	0,258-0,296
AL034P	7/8	5/64	22,22	1,98	0,325-0,370
AL039	1	5/128	25,40	0,90-1,05	0,185-0,216
AL039M	1	3/64	25,40	1,05-1,25	0,220-0,255
AL040L	1	7/128	25,40	1,25-1,45	0,256-0,295
AL040M	1	1/16	25,40	1,45-1,65	0,296-0,335
AL040P	1	9/128	25,40	1,65-1,95	0,336-0,385
AL053	1.1/8	3/64	28,50	1,19	0,274-0,305
AL029L	1.1/4	5/128	31,75	1,00	0,261-0,311
AL029P	1.1/4	1/16	31,75	1,58	0,385-0,433
AL117	2	1/16	50,80	1,58	0,627-0,708
AL122	1.1/8	1/8	28,60	3,20	0,620-0,758
AL035	2	1/2	50,80	12,70	3,960

*Algumas medidas em polegada estão em valores aproximados.

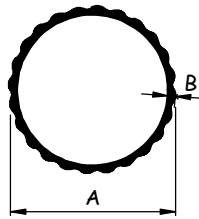

CÓDIGO	POLEGADA		MILÍMETROS		PESO (kg/m)
	A	B	A	B	
AL059	7/8	5/128	22,22	1,00	0,148
*Algumas medidas em polegada estão em valores aproximados.					



CÓDIGO	POLEGADA	MILÍMETROS	PESO (kg/m)
	A	A	
AL045	1/4	6,35	0,086
*Algumas medidas em polegada estão em valores aproximados.			

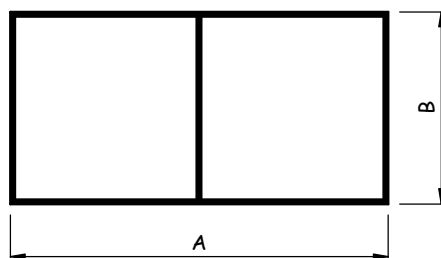

CÓDIGO	POLEGADA*		MILÍMETROS		PESO (kg/m)
	A	B	A	B	
AL021L	1.57/64	15/16	48	24	0,350-0,410
AL022L	2	1	50,8	25,4	0,330-0,400
AL023M	2	1	50,8	25,4	0,410-0,500
AL027P	2	1	50,8	25,4	0,510-0,590
AL028EP	2	1	50,8	25,4	0,600-0,710

*Algumas medidas em polegada estão em valores aproximados.

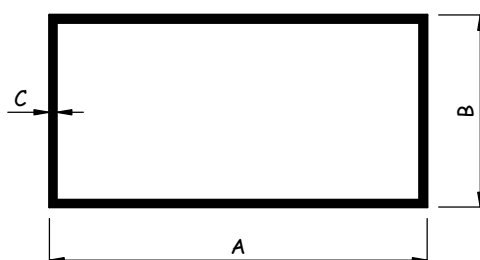

CÓDIGO	POLEGADA*			MILÍMETROS			PESO (kg/m)
	A	B	C	A	B	C	
AL1225	1	1/2	1/16	25,4	12,7	1,40	0,267
AL088	2	1	3/64	50,8	25,4	1,19	0,380
AL10050L	4	2	1/16	101,6	50,8	1,58	1,200
AL10050M	4	2	5/64	101,6	50,8	2,00	1,540
AL10050P	4	2	3/8	101,6	50,8	3,00	1,659

*Algumas medidas em polegada estão em valores aproximados.

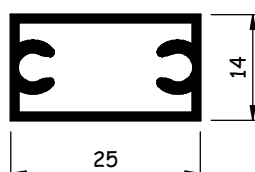

AL1425 (D-082)
0,300 kg/m

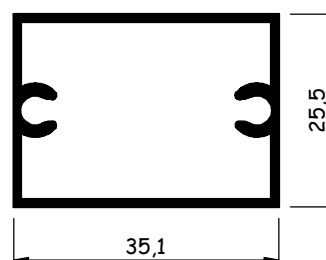

AL2535
0,512 kg/m

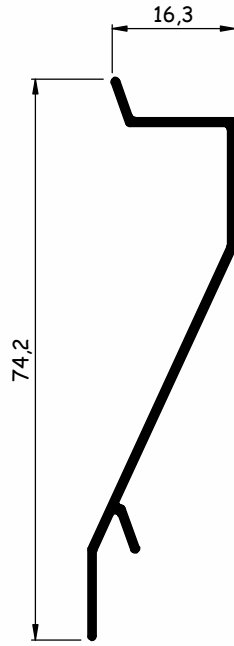

AL123 (VZ023)
0,266 kg/m

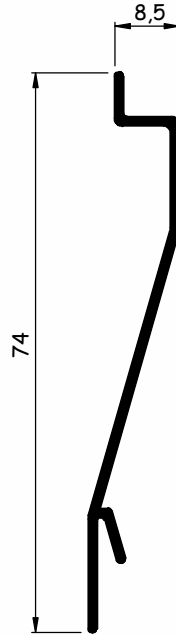

AL124 (VZ024)
0,270 kg/m

VIDRO TEMPERADO 8mm

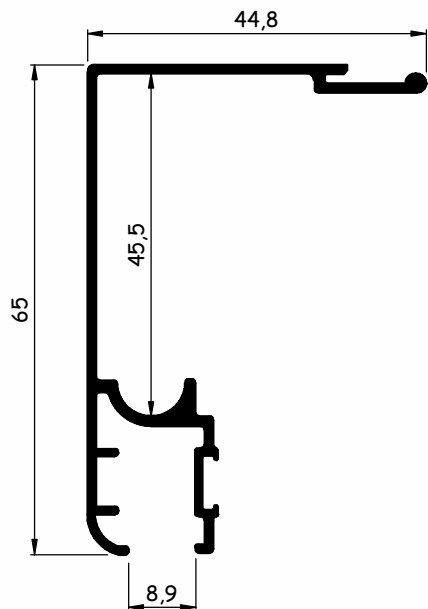

AL880
0,541-605 kg/m

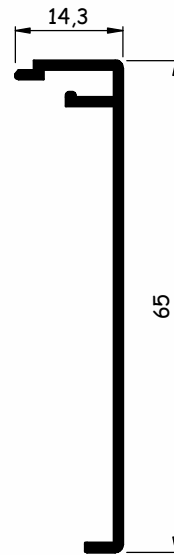

AL881 (BX-132)
0,270 kg/m

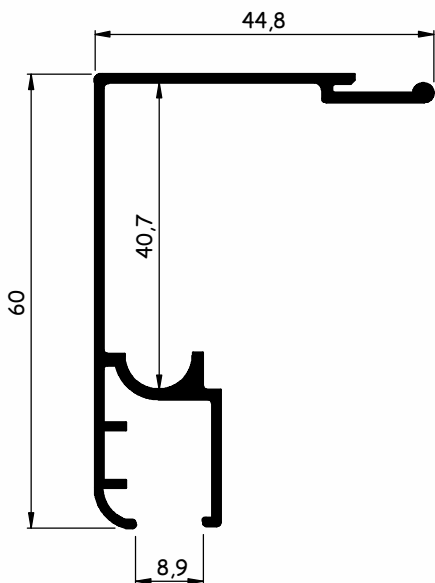

AL870
0,480-0,540 kg/m

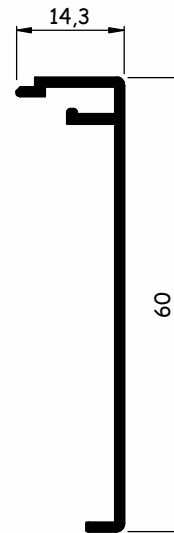

AL860
0,250 kg/m

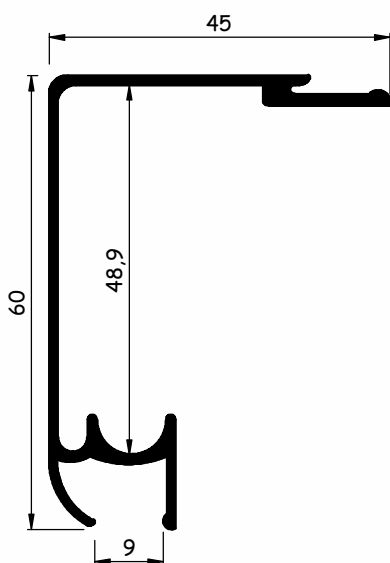

AL873L
0,504 kg/m

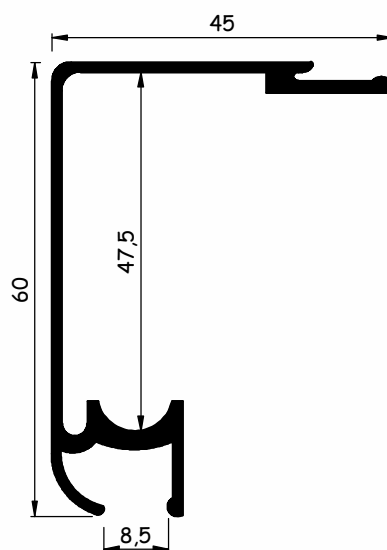

AL873P
0,580 kg/m

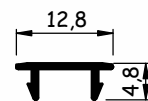

AL882
0,050 kg/m

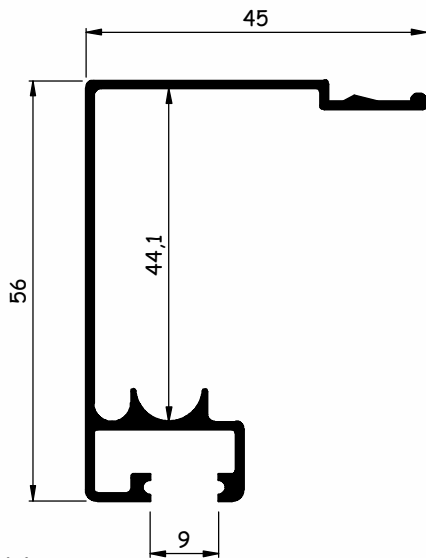

AL861
0,450-0,491 kg/m

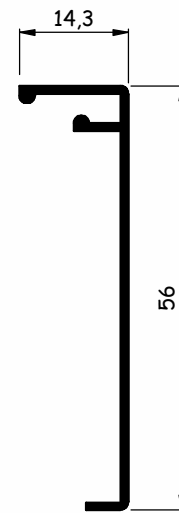

AL859
0,230 kg/m

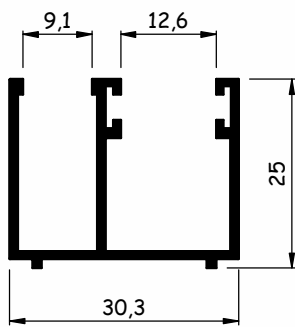

AL822P
0,330 kg/m

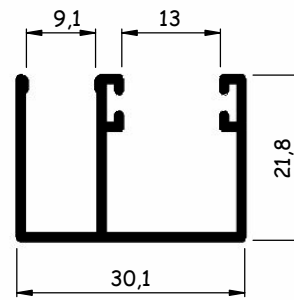

AL822L
0,280 kg/m

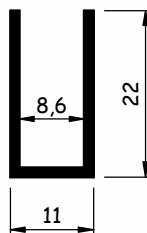

AL839
0,170 kg/m

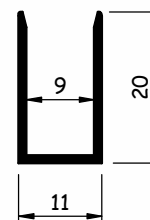

AL841
0,143 kg/m

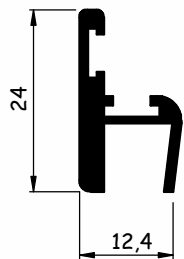

AL879 (CB-266)
0,250 kg/m

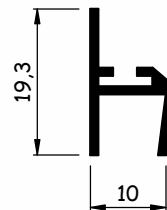

AL878 (BX-232)
0,130 kg/m

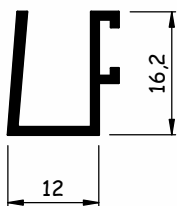

AL825 (CB-275)
0,150 kg/m

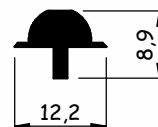

AL1003
0,114 - 0,140 kg/m

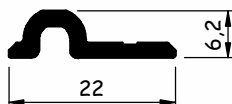

AL1004
0,147 kg/m



AL1006
0,173 kg/m

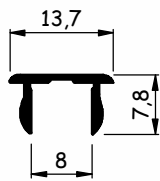

AL883

0,069 kg/m

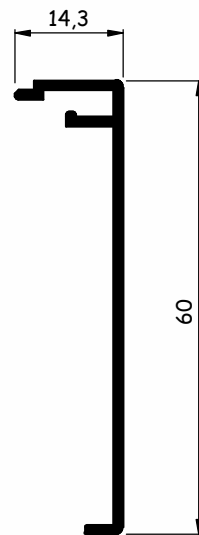

AL860

0,250 kg/m

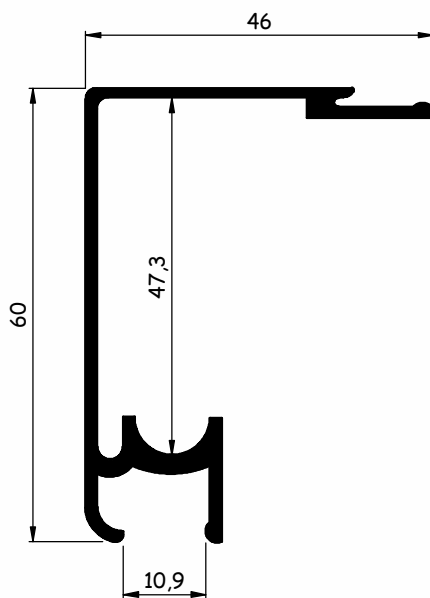

AL871

0,652 kg/m

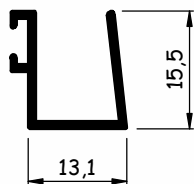

AL884

0,136 kg/m

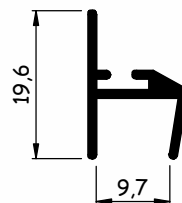

AL885

0,135 kg/m

VIDRO TEMPERADO 10mm

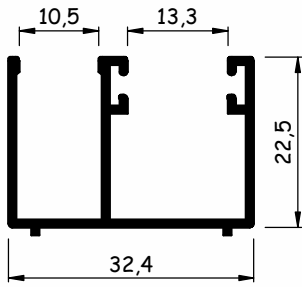

AL824L
0,311 kg/m

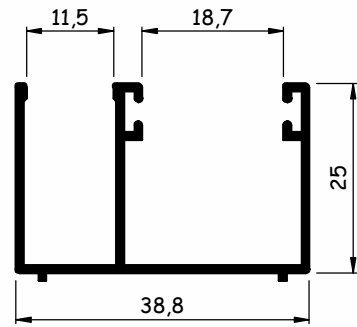

AL824P
0,348 kg/m

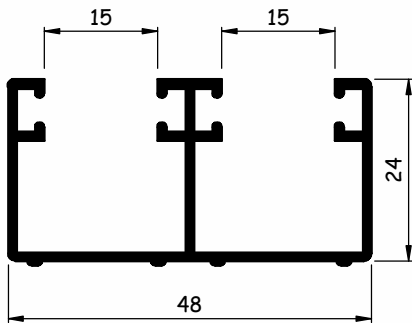

AL820
0,480 kg/m

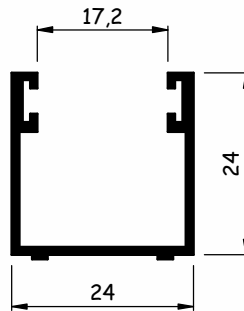

AL821 (BX-069)
0,250 kg/m

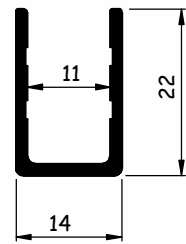

AL838L 0,125 - 0,145 kg/m
AL838P 0,155 - 0,180 kg/m

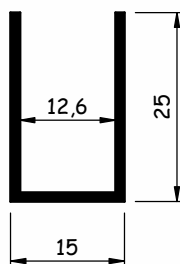

AL555 (PU-344)
0,210 kg/m

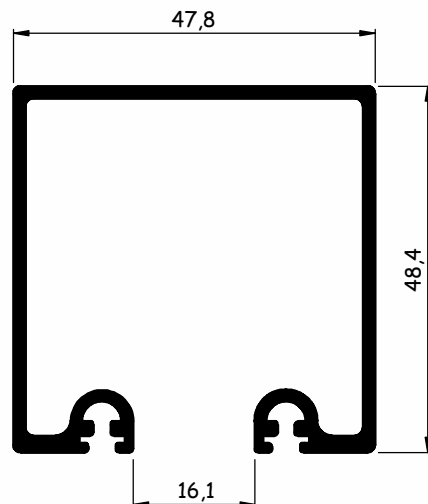

AL823
0,873 kg/m

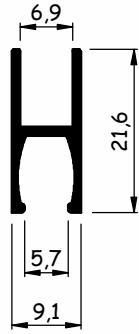

AL224
0,180 kg/m

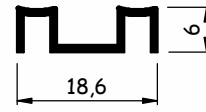

AL294 (DS-294)
0,110 kg/m

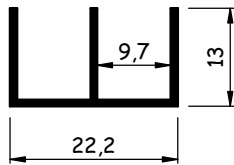

AL270
0,170 kg/m

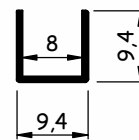

AL036
0,050 kg/m

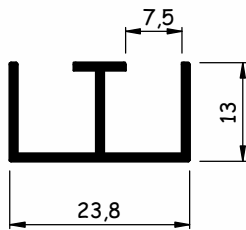

AL295
0,177 kg/m

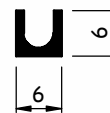

AL033 (CG105)
0,050 kg/m

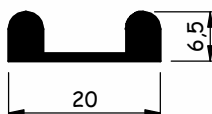

AL296
0,176 kg/m

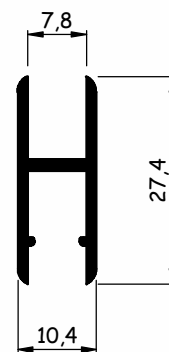

AL297
0,221 kg/m

